

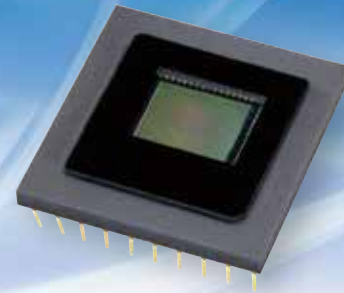

# SXGA ultra high sensitivity CMOS image sensor

# BT130C



## Description

BT130C is a 1.3-megapixels (Type 2/3) ultra high sensitivity CMOS image sensor. It is capable of capturing fine color images even in a very low light condition under 0.01Lux which is equivalent to a star-filled night. Brookman Technology's creative Hyper Bit® ADC achieves an image with low temporal noise and wide dynamic range (>80dB@intra-scene). BT130C is mounted in a 65-pin CPGA package and unnecessary to operate with a large cooling device so that this chip is able to integrate in a handy camera system easily.

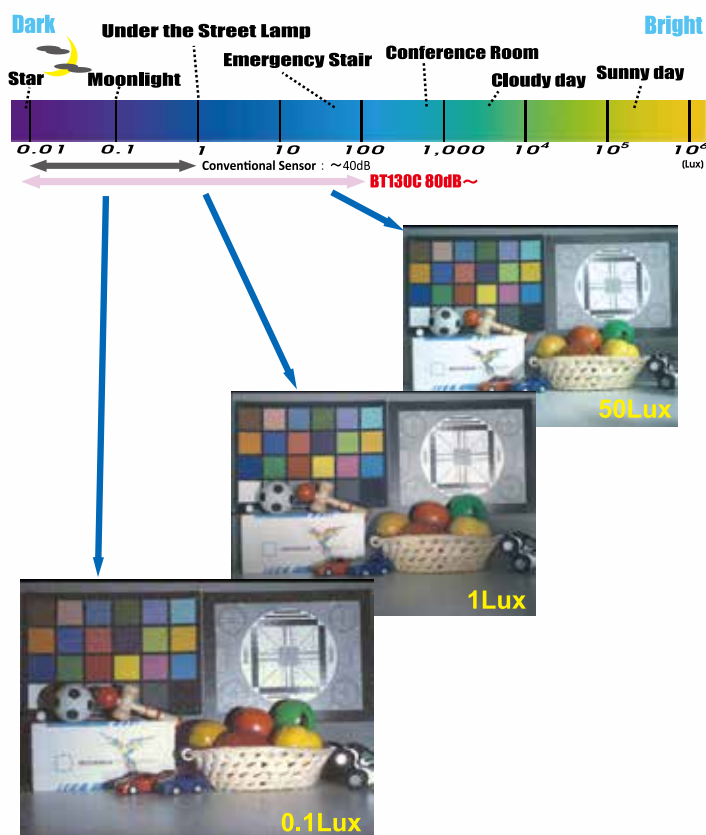

## Features

- SXGA resolution: 1288(H) x 1032(V)
- Optical format: Type 2/3
- Active pixel area: 9.1mm(H)x7.3mm(V), 11.7mm(D)
- High sensitivity and low noise performance
- Electronic rolling shutter
- On-chip 18-bit Hyper Bit® ADC (Folding integration and Cyclic ADC)
- Windowing (Vertical only)
- Capable of slave mode with external horizontal sync. and vertical sync. signals
- Low power consumption (<600mW)
- Power supply of 3.3V/1.8V
- Available in color (Bayer RGB) and monochrome sensor

## Applications

- Low-light imaging camera
- Professional broadcast
- Medical application
- Scientific experiment
- Security and Surveillance
- Industrial inspection
- Machine vision

For all product and custom CIS design inquiries, feel free to contact us below.

**Brookman Technology, Inc.** 125 Daikumachi, Nakaku, Hamamatsu, 430-0936 Japan

Website:<http://brookmantech.com> Tel: +81-53-482-7741 Email:[bt\\_request@brookmantech.com](mailto:bt_request@brookmantech.com)



### Specifications

Optical format	2/3 Type
Pixel size	7.1µm x 7.1µm
Total pixels	1408(H) x 1042(V)
Effective pixels	1288(H) x 1032(V)
Pixel type	Pinned 4Trs.
Shutter	Electronic rolling shutter
Windowing(ROI)	Available(V-direction only)
ADC resolution	On-chip 18-bit
Frame rate	30fps
Output interface	4-lane LVDS
Data rate	Max. 270Mbps/lane
Full well capacity	13ke-
Dynamic range	>80dB
SNR(Max.)	41dB
Dark noise	1.2e-
Sensitivity	18.0V/lux*s (Mono) 8.4V/lux*s (Green)
PRNU	<1.2%@Half Saturation
Q.E.	74%@Mono (λ=550nm)
Power supply	1.8V and 3.3V
Power consumption	<600mW
Package type	65-pin CPGA
Chroma	Monochrome and Bayer RGB
Input clock rate	45MHz

### Q.E. Curve

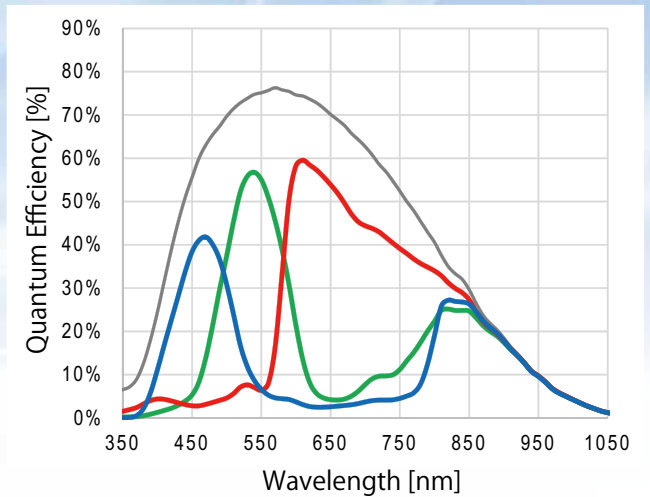

### Block Diagram

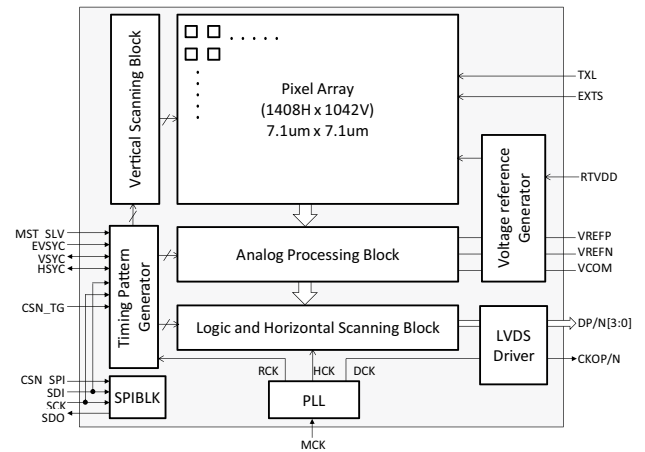

### Sensor Package

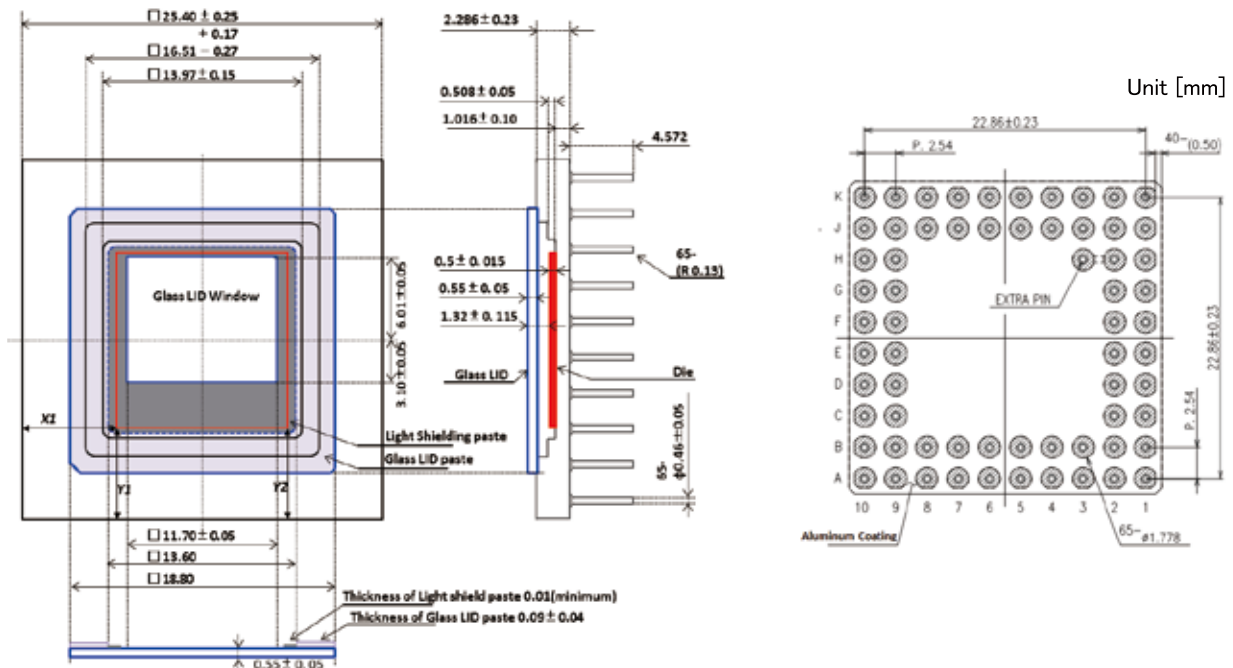

For all product and custom CIS design inquiries, feel free to contact us below.

**Brookman Technology, Inc.** 125 Daikumachi, Nakaku, Hamamatsu, 430-0936 Japan

Website: <http://brookmantech.com> Tel: +81-53-482-7741 Email: [bt\\_request@brookmantech.com](mailto:bt_request@brookmantech.com)

