



1/2.7" FHD Single chip CMOS Image Sensor with 1920x1080 Pixel Array

PO2210N

Rev 0.0

Last Update : 08. Sep. 2015

6th Floor, 105, Gwanggyo-ro, Yeongtong-gu, Suwon-si, Gyeonggi-do, 443-270, Korea
TEL +82-31-888-5300 | FAX +82-31-888-5370

Copyright 2014. Pixelplus Co., Ltd.
ALL RIGHTS RESERVED

▶ Features

- ▷ 1936 x 1096 effective pixel array with RGB Bayer color filters and micro-lens.
 - ▷ Power supply : 3.3V (Core 1.6V)
 - ▷ Input. Clock Frequency : 27MHz
 - ▷ Output formats :
 - ◆ Digital Output mode :
 - max. FHD (1920x1080) YCbCr422/RGB565/RGB444.
 - ✓ progressive, 10 bits parallel 30 fps @ 148.5 MHz
 - ✓ progressive, BT1120 30fps @ 74.25 MHz
 - max. FHD (1920x1080) Bayer
 - ✓ progressive, 10 bits parallel 30fps @ 74.25 MHz
 - ◆ Digital Output interface :
 - 20/16 Bits parallel with BT1120
 - 8/10 Bits Parallel interface YCbCr422/RGB565/RGB444
 - ▷ Image processing on chip : lens shading, gamma / defect /color correction, low pass filter, color interpolation, edge enhancement, brightness, contrast, de-color, special effects, auto black level , auto white balance, auto exposure control and back light compensation.
 - ▷ Frame size, window size and position can be programmed through a 2-wire serial interface bus
 - ▷ Free scaling(up & down)
 - ▷ Smart Contrast(SC) : Adaptive DWDR & Contrast
 - ▷ Selective Color Shift
 - ▷ PlusPixel4.0™ Technology Applied
 - ▷ High Image Quality and High low light performance
- ▷ I2C /SPI master included
 - ▷ 4 layer overlay functions by using SPI ROM
 - ▷ Scan mode : Progressive Scan
 - ▷ On-chip phase locked loop (PLL)
 - ▷ Horizontal / Vertical mirroring
 - ▷ Cropping & max 4X digital Zoom support
 - ▷ 50Hz, 60Hz flicker automatic cancellation
 - ▷ Software Reset
 - ▷ Smart IR-LED controller
 - ▷ TDN(moving) filter/IRIS control
 - ▷ Motion detection support (64-area)
 - ▷ Chip address selection PAD
 - ▷ Crystal input support
 - ▷ 64CLCC Package type supports

► Features

Parameter	Typical Value
Effective Pixel Array	1936 (H) x 1096 (V)
Pixel Size	3.0 um x 3.0 um
Effective Image Area	5.808 mm x 3.288 mm (Diagonal : 6.674mm)
Optical Format	1/2.7 inch
Input. Clock Freq.	27 MHz
Output. Clock Freq.	74.25MHz
Output Interface	- 20/16 Bits parallel with BT1120 - 8/10 Bits Parallel interface
Max. Frame Rate	30 fps @YUV
Power Supply	Analog & IO : 3.3V Core : 1.6V

Parameter	Typical Value
Application	Analog HD, Car Black Box, HD-CCTV, IP Cam, Rear View, Smart TV, Door Phone etc.
Power Consumption	663.3 mW @Dynamic
	635.8 uW @Standby
Operating Temp. (Fully Functional Temp)	-40 ~ 85 [°C]
Dynamic Range	TBD [dB]
SNR	TBD [dB]

[Table 1] Typical Parameters

▶ Signal Environment

PO2210N don't have tolerant Input pads. The input signal must be equal to HVDD for stable operation. If the power of input signal is higher than recommended, it may flow leakage current by shot circuit path in the input PADS.

▶ Chip Architecture

PO2210N has 1936 x 1096 effective pixel array and column/row driver circuits to read out the pixel data progressively. CDS circuit reduces noise signals generated from various sources mainly resulting from process variations. Pixel output is compared with the reset level of its own and only the difference signal is sampled, thus reducing fixed error signal level. Each of R, G, B pixel output can be multiplied by different gain factors to balance the color of images in various light conditions. The analog signals are converted to digital forms one line at a time and 1 line data are streamed out column by column. The Bayer RGB data are passed through a sequence of image signal processing blocks to finally produce YCbCr 4:2:2 output data. Image signal processing includes such operations as gamma correction, defect correction, low pass filter, color interpolation, edge enhancement, color correction, contrast stretch, color saturation, white balance, exposure control and back light compensation. Internal functions and output signal timing can be programmed simply by modifying the register files through 2-wire serial interface.

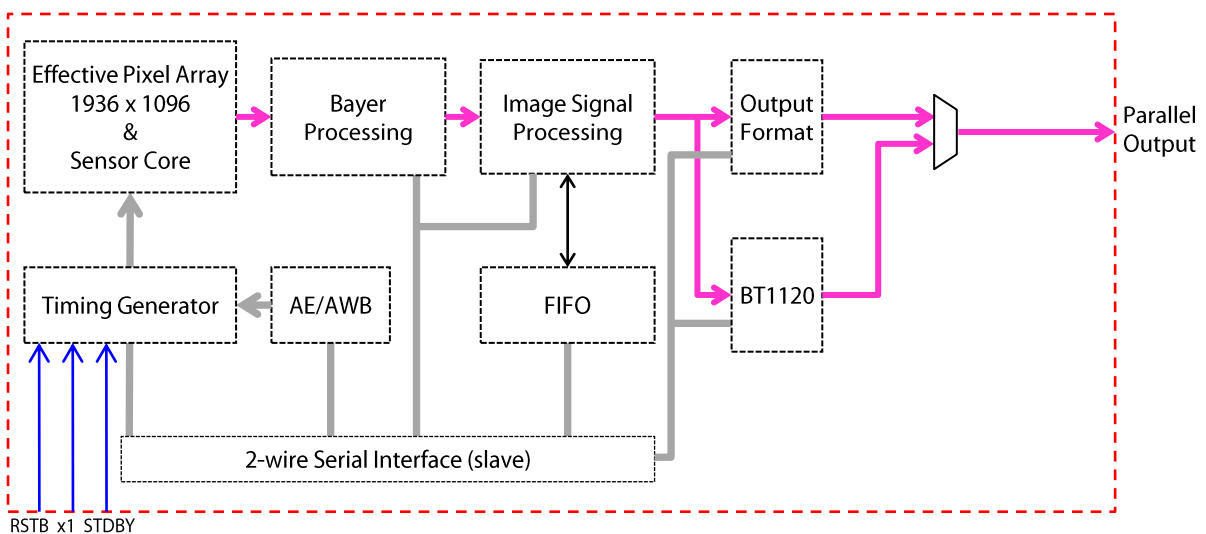

[Fig. 1] Block Diagram



6th Floor, 105, Gwanggyo-ro, Yeongtong-gu, Suwon-si, Gyeonggi-do, 443-270, Korea
TEL +82-31-888-5300 | FAX +82-31-888-5370