

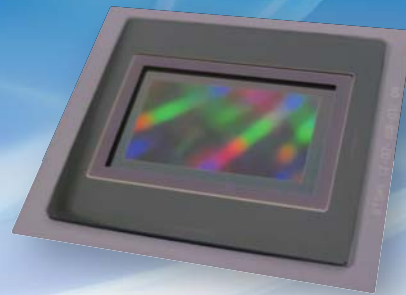

## 8K UHD / 8K Super Hi-Vision CMOS image sensor

# BT3300N



### Description

BT3300N is the world's first 33-megapixels, 8K full-spec. Super Hi-Vision (also known as 8K Ultra High Definition Television conforming to ITU-R Rec. BT.2020) CMOS image sensor. It offers up to 120 fps at 8K ultra high definition with wide dynamic range, very low noise and low power consumption based on Brookman Technology, Inc. patented CMOS imaging sensor technology. BT3300N provides an 8K outstanding immersive image for the next generation vision system.

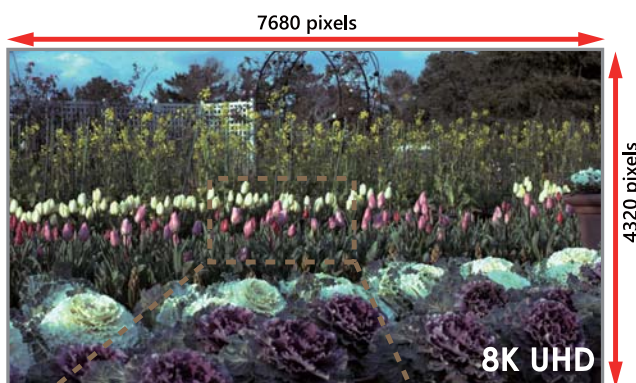

16x digital zoom

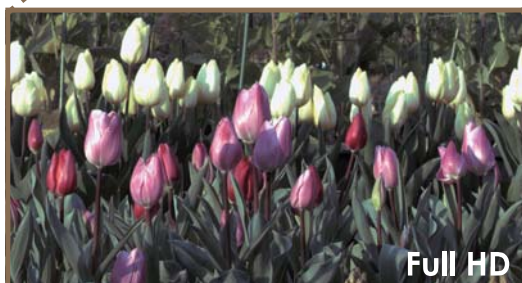

### Features

- 8K full-spec. Super Hi-Vision (8K UHD TV), 7688(H) x 4328(V)
- Active pixel area: 24.6mm(H) x 13.9mm(V), 28.3mm(D)
- Frame rates at up to 120 fps
- Electronic rolling shutter
- Slave mode with external horizontal sync. and vertical sync. signals
- 14-bit high speed and low power column ADC
- 16-channel SLVS data output
- Low power consumption
- Available in color (Bayer RGB) and monochrome sensor

### Applications

- Professional broadcast
- Medical surgery
- Scientific experiment
- Security and Surveillance
- Industrial inspection
- Instrumentation

For all product and custom CIS design inquiries, feel free to contact us below.

**Brookman Technology, Inc.** 125 Daikumachi, Nakaku, Hamamatsu, 430-0936 Japan

Website: <http://brookmantech.com> Tel: +81-53-482-7741 Email: [bt\\_request@brookmantech.com](mailto:bt_request@brookmantech.com)



### Specifications

Optical format	Super 35mm
Pixel size	3.2μm x 3.2μm
Total pixels	7936(H) x 4412(V)
Effective pixels	7688(H) x 4328(V)
Pixel type	Pinned 4Trs.
Shutter	Electronic rolling shutter
ADC resolution	14-bit on-chip
Frame rate	60fps(typ.) and up to 120fps
Output Interface	SLV5 16-Ch. (4 data lane/Ch)
Data rate	1Gbps/lane@120fps
Full well capacity	18ke-
Dynamic range	>68dB
SNR(Max.)	42dB
Dark noise	<7e-@60fps, <8e-@120fps
Sensitivity	>1.7 V/lux·sec (color-green)
PRNU	1.5%@Half saturation
Q.E.	80%@mono (λ =470nm) 70%@green (λ =530nm)
Power supply	1.2V, 1.8V, 2.8V and 3.8V
Power consumption	<3W@60fps and <3.8W@120fps
Package type	816-pin LGA and BGA
Chroma	Monochrome and Bayer RGB
Input clock rate	17.8MHz (typ.)

### Q.E. Curve

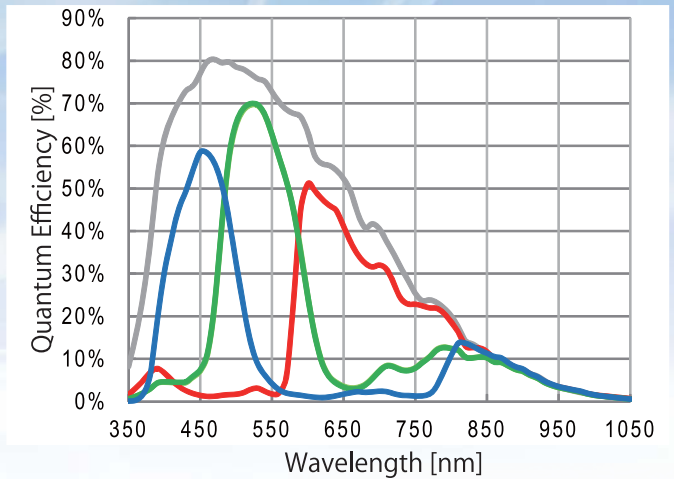

### Block Diagram

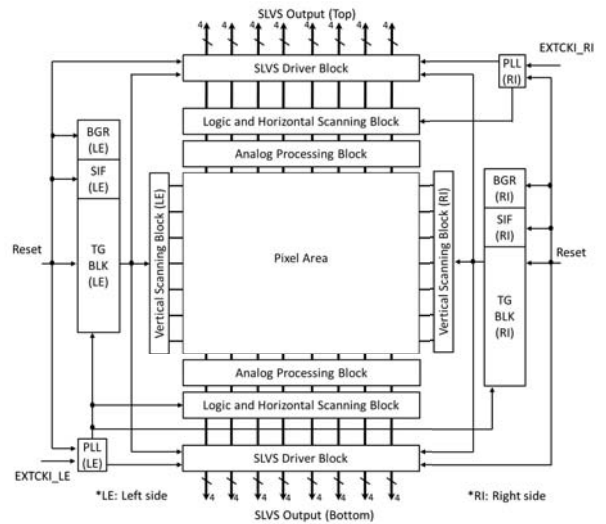

### Sensor Package

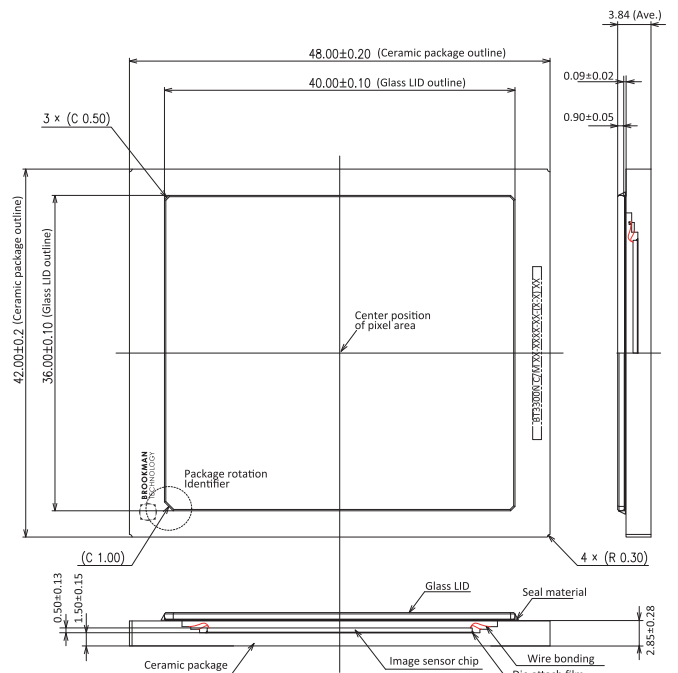
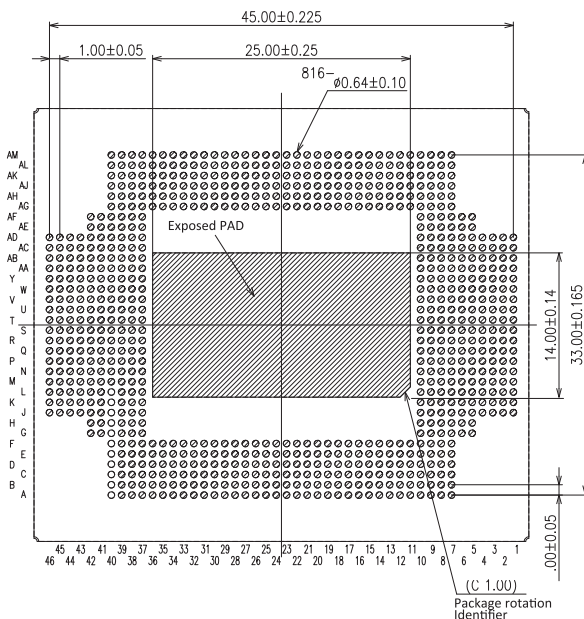

For all product and custom CIS design inquiries, feel free to contact us below.

**Brookman Technology, Inc.** 125 Daikumachi, Nakaku, Hamamatsu, 430-0936 Japan

Website: <http://brookmantech.com> Tel: +81-53-482-7741 Email: [bt\\_request@brookmantech.com](mailto:bt_request@brookmantech.com)

